

ActStrip Border Lighting *Advanced Lighting Solution*

LIGHTING

FEATURES



Energy Saving
Up to 90%



Enhanced Fire &
Health Safety



No Glass /
Shock-Resistant



Longer Lifetime



Virtually
Maintenance-Free



No Fluorescent Cold
Start Problem



Easy Installation
Design

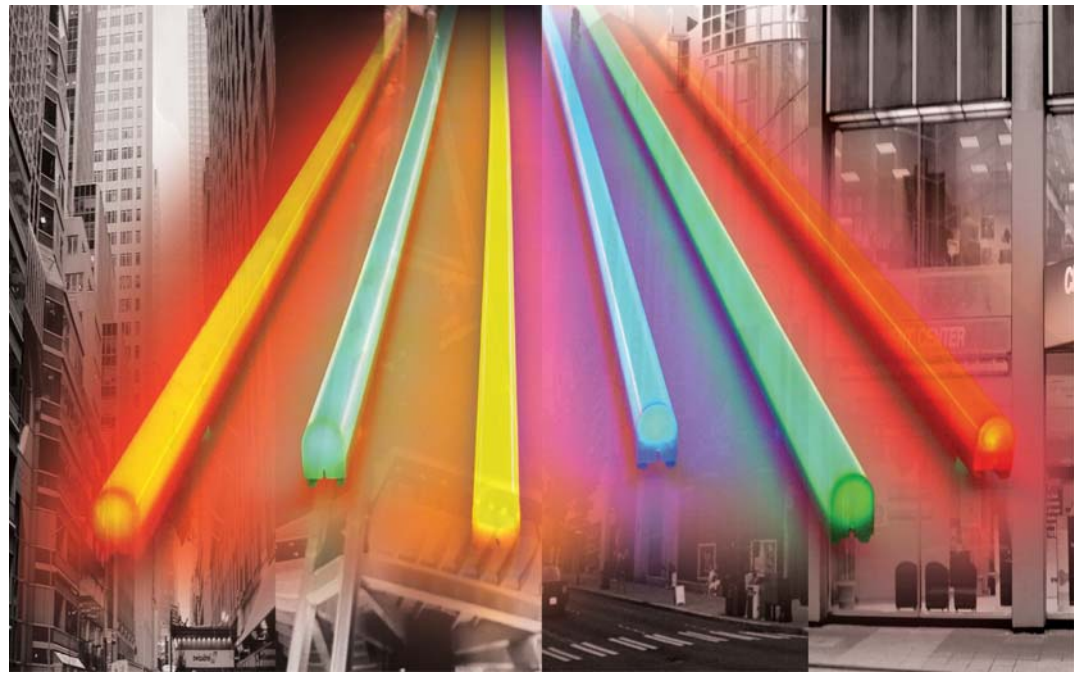

Act One Communications introduces ActStrip, a brand-new lighting solution for building border lights. Thanks to our advanced Light-Emitting Diode (LED) technology, the ActStrip light source has several key advantages, such as extremely low power consumption, lower cost of ownership, and extraordinary safety. These advantages simply make the ActStrip LED light unit a better alternative to neon and fluorescent lights.

Features

The LED light unit eliminates the need for the high voltage power as with neon lights, and thus improves greatly in fire and health safety. The LED lighting is tremendously energy-efficient comparing to fluorescent and neon lights, up to 90% power saving. Our LED components are rated at 100,000 hours, or 11 years, of lifetime expectancy of continuous use. This makes ActStrip virtually maintenance-free, and a much more cost-effective investment than fluorescent and neon lights, which have typically 5,000 to 20,000 hours of lifetime only.

ActStrip light unit does not have any glass material, and therefore makes it a rugged construction and resistant to shock damages. LED light unit glows immediately when

the power is turned on, which means it does not have cold start problems that come with fluorescent and neon lights.

Installation

ActStrip is designed for easy installation for both new buildings and existing border light retrofit. Each ActStrip unit is 8-ft long, and can be connected or cut to any desired length. The LED lighting source generates little heat and thus does not require special mounting parts. The ActStrip units are energized by our field-proven high performance power transformers, which converts AC source into low-voltage power.

Colors

The followings are available colors of ActStrip Border Lights. Transparent (clear) tub covers are also available. Please contact us for more information.

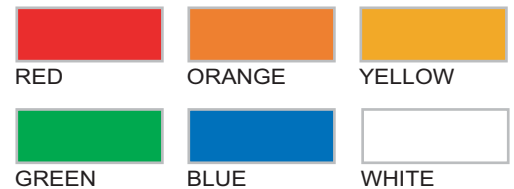

WHITE Border Light Available in Various Color Temperatures



Act One Communications

288 Mayo Avenue, City Of Industry, CA 91789 909.595.6555 1-888-ACTONE1 www.ActOneLED.com

© 2004 Act One Communications, Inc. All rights reserved. Printed in USA. 06/2004. Form No. FO-LNR-BL.

SEE REVERSE FOR SPECIFICATIONS

Mechanical Characteristics

Outside Diameter	Typical	Units
Semicircular	26.0	mm

(1 inch)

Electrical Characteristics

Parameter	Typical	Units
Voltage		
Red-Orange-Yellow	12	VAC
Blue-Green-White	24	VAC
Current		
Red-Orange-Yellow	0.15	A/feet
Blue-Green-White	0.11	A/feet
Max. Run Length	32 / chain	feet
Power Dissipation (Pd)		
Red, Yellow, Orange	1.80	W/feet
Blue, Green, White	2.64	W/feet

Temperature Ratings

Storage Temperature	
Power Supply	-20°C to + 85°C
All other components	-40°C to + 100°C
Operating Temperature	
Power Supply	-10°C to + 60°C

Note :
LBL-W01X-A (X → tube color)

Optical Characteristics

Dominant Wavelength (l dom)	Typical	Units
Red	625	nm
Yellow	592	nm
Orange	605	nm
Green	525	nm
Blue	470	nm
White	5500	K

White available in other color temperatures

Luminance (L)	Typical	Units
Red	400	mcd/m ²
Yellow	550	mcd/m ²
Orange	430	mcd/m ²
Green	140	mcd/m ²
Blue	55	mcd/m ²
White	55	mcd/m ²

Note :

1. Test device : SPECTRASCAN (made by POTO RESEARCH PR-650)
2. Test condition : We test 60cm light bar by photometer and record the intensity per 3cm.

Selection Guide

Part Number	Color	Unit
LBL-W01R-A	Red	8 feet
LBL-W01Y-A	Yellow	8 feet
LBL-W01O-A	Orange	8 feet
LBL-W01G-A	Green	8 feet
LBL-W01B-A	Blue	8 feet
LBL-W01W-A	White	8 feet

Note :

The ActStrip Border Lighting can be cut to the desired length when ordered.

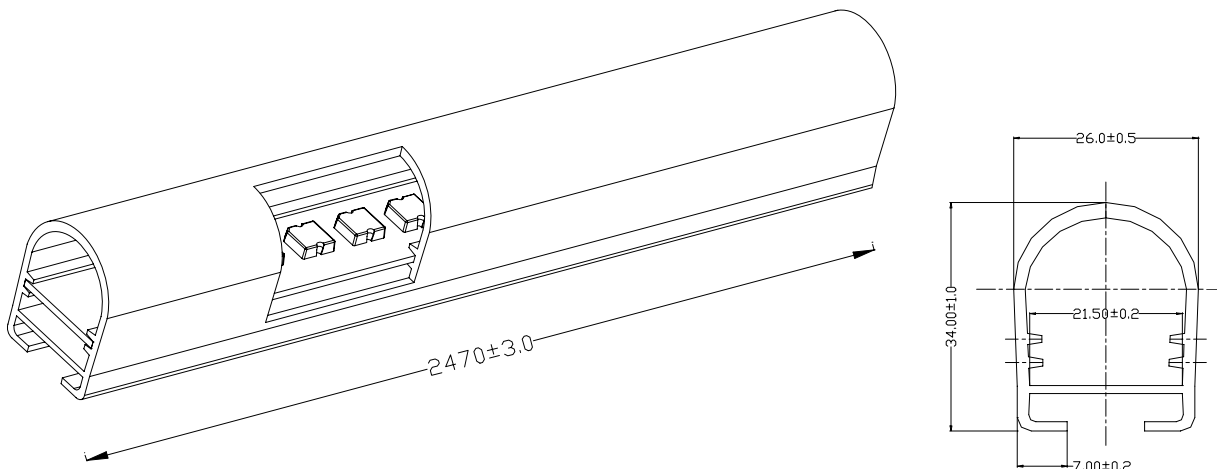

unit: mm